

**RASEY35-XL-N**

Plummer block housing unit

Plummer block housing units RASEY, cast iron housing, radial insert ball bearing with grub screws in inner ring, R seals

X-life

Technical information

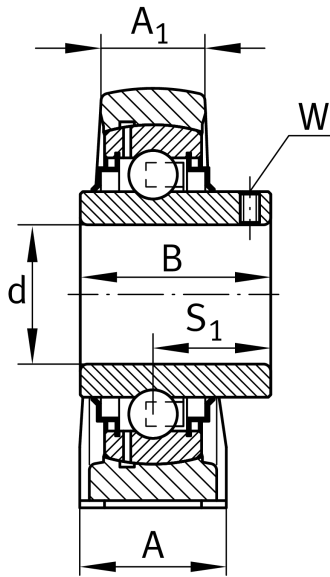

Your current product variant

Material	GG	Grey cast iron
Groove	N	Cast iron housing with undercut slot for end caps

Main Dimensions & Performance Data

d	35 mm	Bore diameter
L	163 mm	Length total
H ₂	93 mm	Height
≈m	1,55 kg	Weight

Mounting dimensions

J	126 mm	Distance fixing bore
N	14 mm	Width (slot)
N ₁	21 mm	Length (slot)



Dimensions

H	47,6 mm	Distance shaft axis
A	45 mm	Width (base)
A ₁	27 mm	Width (head)
H ₁	19 mm	Height (base)
B	42,9 mm	Width
S ₁	25,4 mm	Distance of raceway to locking collar
Q	M6	Connection thread for lubrication

Additional information

ASE07	Housing
GYE35-XL-KRR-B	Bearing designation
KASK07	Protecting cap

Temperature range

T _{min}	-20 °C	Operating temperature min.
T _{max}	120 °C	Operating temperature max.