

**RASE35-XL-N-FA125**

## Plummer block housing unit

Plummer block housing units RASE...-FA125, cast iron housing, radial insert ball bearing with eccentric locking collar, R seals, with anti-corrosion protection

X-life

## Technical information



## Your current product variant

Material	GG	Grey cast iron
Groove	N	Cast iron housing with undercut slot for end caps
Manufacturing instruction	FA125	Unit with Corrotect coating, corrosion-resistant

## Main Dimensions &amp; Performance Data

d	35 mm	Bore diameter
L	163 mm	Length total
H <sub>2</sub>	93 mm	Height
≈m	1,689 kg	Weight

## Mounting dimensions

J	126 mm	Distance fixing bore
N	14 mm	Width (slot)
N <sub>1</sub>	21 mm	Length (slot)

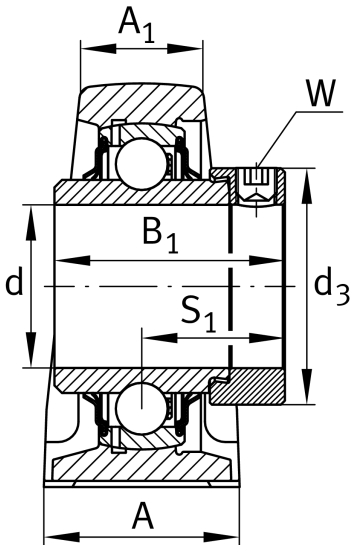



### Dimensions

H	47,6 mm	Distance shaft axis
A	45 mm	Width (base)
A <sub>1</sub>	27 mm	Width (head)
H <sub>1</sub>	19 mm	Height (base)
B <sub>1</sub>	51,3 mm	Locking collar total width
S <sub>1</sub>	32,5 mm	Distance of raceway to locking collar
Q	M6	Connection thread for lubrication

### Additional information

ASE07-FA125	Housing
GE35-XL-KRR-B-FA125	Bearing designation
KASK07	Protecting cap

### Temperature range

T <sub>min</sub>	-20 °C	Operating temperature min.
T <sub>max</sub>	120 °C	Operating temperature max.