

**TFE40-XL**

## Flanged housing unit

Housing units TFE, four-bolt flanged housing units, cast iron, centring spigot, eccentric locking collar, T seals

X-life

## Technical information

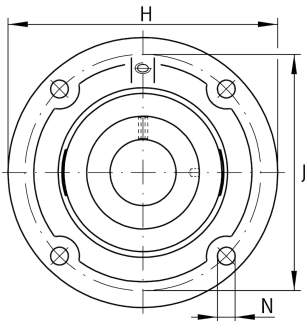
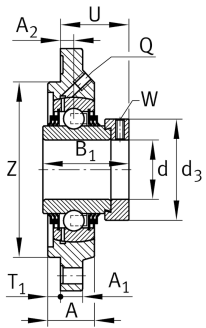

## Your current product variant

|          |    |                |
|----------|----|----------------|
| Material | GG | Grey cast iron |
|----------|----|----------------|

## Main Dimensions &amp; Performance Data

|                 |          |                                   |
|-----------------|----------|-----------------------------------|
| d               | 40 mm    | Bore diameter                     |
| H               | 145 mm   | Height flange                     |
| H               | 145 mm   | Flange width                      |
| U               | 46,6 mm  | Total height unit                 |
| C <sub>r</sub>  | 34.500 N | Basic dynamic load rating, radial |
| C <sub>0r</sub> | 19.800 N | Basic static load rating, radial  |
| C <sub>ur</sub> | 840 N    | Fatigue load limit, radial        |
| ≈m              | 1,71 kg  | Weight                            |

## Mounting dimensions

|                |         |                               |
|----------------|---------|-------------------------------|
| J              | 120 mm  | Pitch circle diameter (holes) |
| N              | 11,5 mm | Fixing bore                   |
| T <sub>1</sub> | 4 mm    | Height spigot                 |
| Z              | 100 mm  | Diameter spigot               |
|                | h8      | Diameter spigot clearance     |
| W              | 5 mm    | Width across flats            |
| n              | 4       | Number of screwing holes      |



### Dimensions

|                |         |                                   |
|----------------|---------|-----------------------------------|
| A              | 28 mm   | Height housing                    |
| A <sub>1</sub> | 11,5 mm | Thickness of flange               |
| A <sub>2</sub> | 11,5 mm | Distance raceway                  |
| B <sub>1</sub> | 56,5 mm | Locking collar total width        |
| Q              | M6      | Connection thread for lubrication |
| d <sub>3</sub> | 58 mm   | Outer diameter locking collar     |

### Additional information

|               |                     |
|---------------|---------------------|
| GEHFE08-GG-N  | Housing             |
| GE40-XL-KTT-B | Bearing designation |

### Temperature range

|                  |        |                            |
|------------------|--------|----------------------------|
| T <sub>min</sub> | -20 °C | Operating temperature min. |
| T <sub>max</sub> | 100 °C | Operating temperature max. |