

**RCJ55-XL**

Flanged housing unit

Housing units RCJ, four-bolt flanged housing units, cast iron, eccentric locking collar, R seals

X-life

Technical information

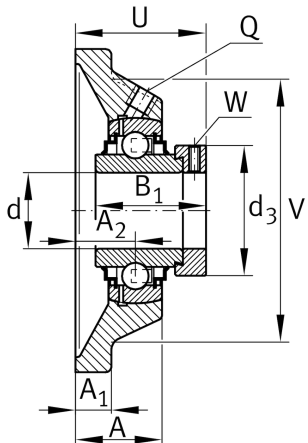

Your current product variant

Material	GG	Grey cast iron
----------	----	----------------

Main Dimensions & Performance Data

d	55 mm	Bore diameter
L	162 mm	Flange width
U	74,6 mm	Total height unit
C _r	46.000 N	Basic dynamic load rating, radial
C _{0r}	29.000 N	Basic static load rating, radial
C _{ur}	1.240 N	Fatigue load limit, radial
≈m	3,48 kg	Weight

Mounting dimensions

J	130 mm	Distance fixing bore
N	18 mm	Fixing bore
n	4	Number of screwing holes



Dimensions

A	43,5 mm	Height housing
A ₁	15 mm	Thickness of flange
A ₂	31 mm	Distance raceway
V	140 mm	Shoulder diameter housing
Q	M6	Connection thread for lubrication
d ₃	76 mm	Outside diameter locking device

Additional information

1	Number of housings
CJ11	Housing
GE55-XL-KRR-B	Bearing designation

Temperature range

T _{min}	-20 °C	Operating temperature min.
T _{max}	120 °C	Operating temperature max.