

**RASE50-XL-N**

Plummer block housing unit

Plummer block housing units RASE, cast iron housing, radial insert ball bearing with eccentric locking collar, R seals

X-life

Technical information



Your current product variant

Material	GG	Grey cast iron
Groove	N	Cast iron housing with undercut slot for end caps

Main Dimensions & Performance Data

d	50 mm	Bore diameter
L	200 mm	Length total
H ₂	115 mm	Height
≈m	2,84 kg	Weight

Mounting dimensions

J	158 mm	Distance fixing bore
N	18 mm	Width (slot)
N ₁	23 mm	Length (slot)

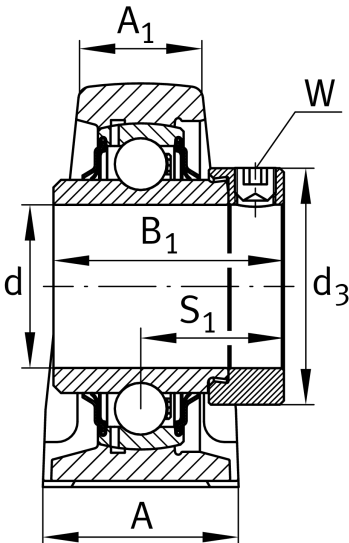



Dimensions

H	57,2 mm	Distance shaft axis
A	54 mm	Width (base)
A ₁	34 mm	Width (head)
H ₁	21,5 mm	Height (base)
B ₁	62,8 mm	Locking collar total width
S ₁	38,2 mm	Distance of raceway to locking collar
Q	M6	Connection thread for lubrication

Additional information

ASE10	Housing
GE50-XL-KRR-B	Bearing designation
KASK10	Protecting cap

Temperature range

T _{min}	-20 °C	Operating temperature min.
T _{max}	120 °C	Operating temperature max.