

**RCJTY50-XL-N**

Flanged housing unit

Housing units RCJTY, two-bolt flanged housing units, cast iron, grub screws in inner ring, R seals

X-life

Technical information

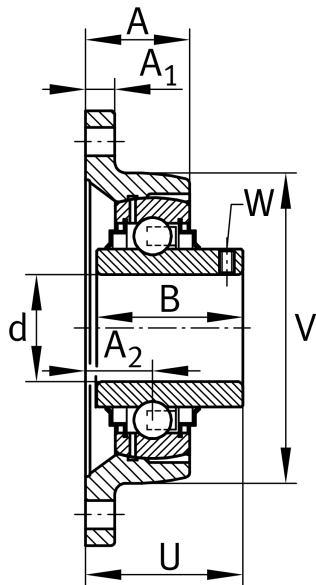

Your current product variant

Groove	N	Cast iron housing with undercut slot for end caps
Material	GG	Grey cast iron

Main Dimensions & Performance Data

d	50 mm	Bore diameter
L	116 mm	Flange width
H	190 mm	Height flange
U	60,6 mm	Total height unit
C _r	37.500 N	Basic dynamic load rating, radial
C _{0r}	23.200 N	Basic static load rating, radial
C _{ur}	990 N	Fatigue load limit, radial
≈m	2 kg	Weight

Mounting dimensions

J	157 mm	Distance fixing bore
N	18 mm	Fixing bore
n	2	Number of screwing holes



Dimensions

A	39 mm	Height housing
A ₁	13 mm	Thickness of flange
A ₂	28 mm	Distance raceway
B	51,6 mm	Width
V	116 mm	Shoulder diameter housing
Q	M6	Connection thread for lubrication

Additional information

1	Number of housings
CJT10-N	Housing
GYE50-XL-KRR-B	Bearing designation
KASK10	Protecting cap

Temperature range

T _{min}	-20 °C	Operating temperature min.
T _{max}	120 °C	Operating temperature max.