

**TASE50-XL-N**

## Plummer block housing unit

Plummer block housing units TASE, cast iron housing, radial insert ball bearing with eccentric locking collar, T seals

X-life

## Technical information



## Your current product variant

Material	GG	Grey cast iron
Groove	N	Cast iron housing with undercut slot for end caps
Material	GG	Cast iron

## Main Dimensions &amp; Performance Data

d	50 mm	Bore diameter
L	200 mm	Length total
H <sub>2</sub>	115 mm	Height
≈m	2,84 kg	Weight

## Mounting dimensions

J	158 mm	Distance fixing bore
N	18 mm	Width (slot)
N <sub>1</sub>	23 mm	Length (slot)

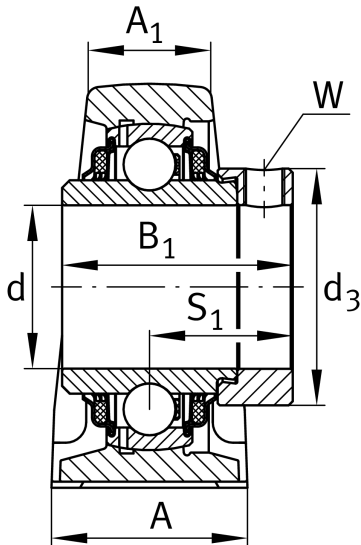



### Dimensions

H	57,2 mm	Distance shaft axis
A	54 mm	Width (base)
A <sub>1</sub>	34 mm	Width (head)
H <sub>1</sub>	21,5 mm	Height (base)
B <sub>1</sub>	62,8 mm	Locking collar total width
S <sub>1</sub>	38,2 mm	Distance of raceway to locking collar
Q	M6	Connection thread for lubrication

### Additional information

ASE10	Housing
GE50-XL-KTT-B	Bearing designation
KASK10	Protecting cap

### Temperature range

T <sub>min</sub>	-20 °C	Operating temperature min.
T <sub>max</sub>	120 °C	Operating temperature max.