

**TFE50-XL-N**

Flanged housing unit

Housing units TFE, four-bolt flanged housing units, cast iron, centring spigot, eccentric locking collar, T seals

X-life

Technical information

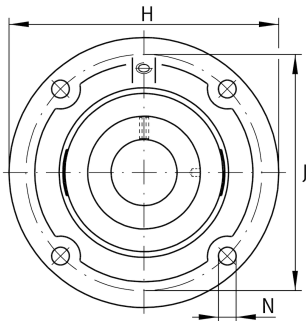
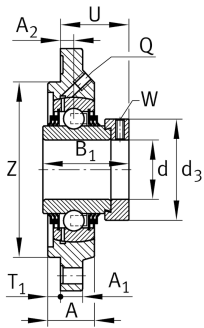

Your current product variant

Groove	N	Cast iron housing with undercut slot for end caps
Material	GG	Grey cast iron

Main Dimensions & Performance Data

d	50 mm	Bore diameter
H	165 mm	Height flange
U	50,7 mm	Total height unit
C _r	37.500 N	Basic dynamic load rating, radial
C _{0r}	23.200 N	Basic static load rating, radial
C _{ur}	990 N	Fatigue load limit, radial
≈m	2,399 kg	Weight

Mounting dimensions

J	136 mm	Pitch circle diameter (holes)
N	14 mm	Fixing bore
T ₁	4 mm	Height spigot
Z	115 mm	Diameter spigot
	h8	Diameter spigot clearance
n	4	Number of screwing holes



Dimensions

A	27,5 mm	Height housing
A ₁	13 mm	Thickness of flange
A ₂	12,5 mm	Distance raceway
B ₁	62,8 mm	Locking collar total width
Q	M6	Connection thread for lubrication

Additional information

1	Number of housings
GEHFE10-GG-N	Housing
GE50-XL-KTT-B	Bearing designation
KASK10	Protecting cap

Temperature range

T _{min}	-20 °C	Operating temperature min.
T _{max}	100 °C	Operating temperature max.