

**RME080-XL**

Flanged housing unit

Housing units RMEO, four-bolt flanged housing units, cast iron, centring spigot, eccentric locking collar, series 63, R seals

X-life

Technical information

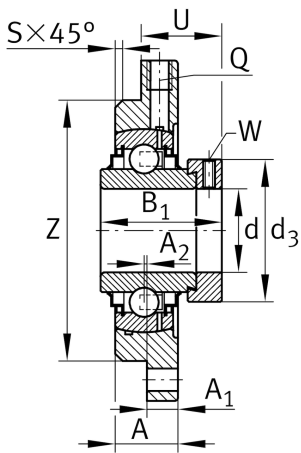
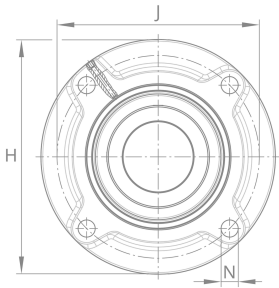

Your current product variant

Material	GG	Grey cast iron
----------	----	----------------

Main Dimensions & Performance Data

d	80 mm	Bore diameter
H	275 mm	Height flange
B ₁	93,6 mm	Locking collar total width
U	56,6 mm	Total height unit
C _r	131.000 N	Basic dynamic load rating, radial
C _{0r}	87.000 N	Basic static load rating, radial
C _{ur}	4.050 N	Fatigue load limit, radial
≈m	12,7 kg	Weight

Mounting dimensions

J	235 mm	Pitch circle diameter (holes)
N	22 mm	Fixing bore
Z	200 mm	Diameter spigot
	h8	Diameter spigot clearance
W	6 mm	Width across flats
n	4	Number of screwing holes



Dimensions

A	51 mm	Height housing
A ₁	12 mm	Thickness of flange
A ₂	3 mm	Distance raceway
S	6 mm	Chamfer width
Q	M6	Connection thread for lubrication

Additional information

1	Number of housings
MEO16	Housing
GNE80-XL-KRR-B-FA107	Bearing designation

Temperature range

T _{min}	-20 °C	Operating temperature min.
T _{max}	120 °C	Operating temperature max.