

**RMEO100-XL**

Flanged housing unit

Housing units RMEO, four-bolt flanged housing units, cast iron, centring spigot, eccentric locking collar, series 63, R seals

X-life

Technical information

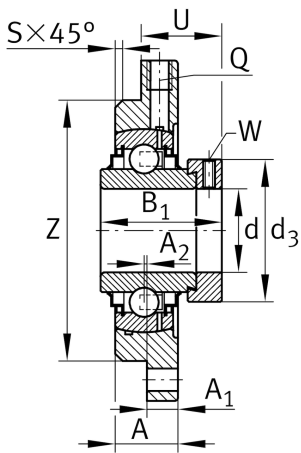
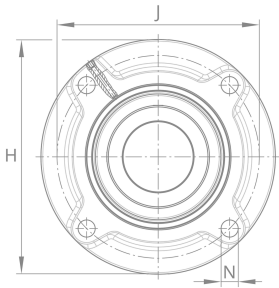

Your current product variant

Material	GG	Grey cast iron
----------	----	----------------

Main Dimensions & Performance Data

d	100 mm	Bore diameter
H	340 mm	Height flange
B ₁	109,4 mm	Locking collar total width
U	68,5 mm	Total height unit
C _r	184.000 N	Basic dynamic load rating, radial
C _{0r}	141.000 N	Basic static load rating, radial
C _{ur}	5.800 N	Fatigue load limit, radial
≈m	21,64 kg	Weight

Mounting dimensions

J	295 mm	Pitch circle diameter (holes)
N	26 mm	Fixing bore
Z	250 mm	Diameter spigot
	h8	Diameter spigot clearance
W	6 mm	Width across flats
n	4	Number of screwing holes



Dimensions

A	57 mm	Height housing
A ₁	27 mm	Thickness of flange
A ₂	1,5 mm	Distance raceway
S	8 mm	Chamfer width
Q	M6	Connection thread for lubrication

Additional information

1	Number of housings
MEO20	Housing
GNE100-XL-KRR-B-FA107	Bearing designation

Temperature range

T _{min}	-20 °C	Operating temperature min.
T _{max}	120 °C	Operating temperature max.