**PASE50-XL-N-FA125** [↗](#)

Plummer block housing unit

Plummer block housing units PASE...-FA125, cast iron housing, radial insert ball bearing with eccentric locking collar, P seals, with anti-corrosion protection

X-life

Technical information

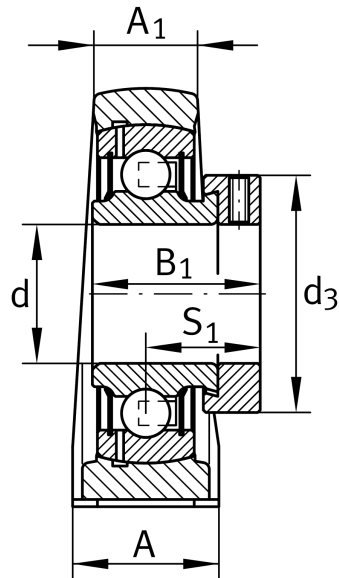
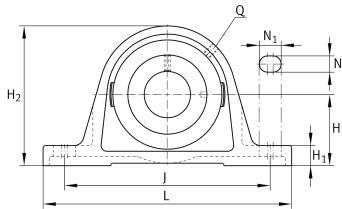

Your current product variant

Material	GG	Grey cast iron
Groove	N	Cast iron housing with undercut slot for end caps

Main Dimensions & Performance Data

d	50 mm	Bore diameter
L	200 mm	Length total
H ₂	115 mm	Height
≈m	2,63 kg	Weight

Mounting dimensions

J	158 mm	Distance fixing bore
N	18 mm	Width (slot)
N ₁	23 mm	Length (slot)



Dimensions

H	57,2 mm	Distance shaft axis
A	54 mm	Width (base)
A ₁	34 mm	Width (head)
H ₁	21,5 mm	Height (base)
B ₁	43,8 mm	Locking collar total width
S ₁	32,8 mm	Distance of raceway to locking collar
Q	M6	Connection thread for lubrication

Additional information

ASE10-FA125	Housing
GRAE50-XL-NPP-B-FA125	Bearing designation
KASK10	Protecting cap

Temperature range

T _{min}	-20 °C	Operating temperature min.
T _{max}	120 °C	Operating temperature max.