

**RME090-XL**

Flanged housing unit

Housing units RME0, four-bolt flanged housing units, cast iron, centring spigot, eccentric locking collar, series 63, R seals

X-life

Technical information

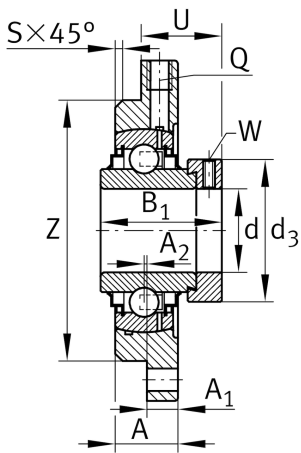
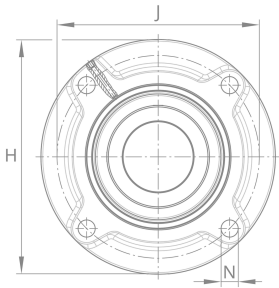

Your current product variant

Material	GG	Grey cast iron
----------	----	----------------

Main Dimensions & Performance Data

d	90 mm	Bore diameter
H	300 mm	Height flange
B ₁	101 mm	Locking collar total width
U	62,5 mm	Total height unit
C _r	151.000 N	Basic dynamic load rating, radial
C _{0r}	107.000 N	Basic static load rating, radial
C _{ur}	3.850 N	Fatigue load limit, radial
≈m	14,95 kg	Weight

Mounting dimensions

J	260 mm	Pitch circle diameter (holes)
N	22 mm	Fixing bore
Z	220 mm	Diameter spigot
	h8	Diameter spigot clearance
W	6 mm	Width across flats
n	4	Number of screwing holes



Dimensions

A	50 mm	Height housing
A ₁	22 mm	Thickness of flange
A ₂	3 mm	Distance raceway
S	6 mm	Chamfer width
Q	M6	Connection thread for lubrication

Additional information

1	Number of housings
MEO18	Housing
GNE90-XL-KRR-B-FA107	Bearing designation

Temperature range

T _{min}	-20 °C	Operating temperature min.
T _{max}	120 °C	Operating temperature max.