

**RSAO100-XL** [↗](#)

Plummer block housing unit

Plummer block housing units RSAO, cast iron housing, radial insert ball bearing with eccentric locking collar, R seals

X-life

Technical information

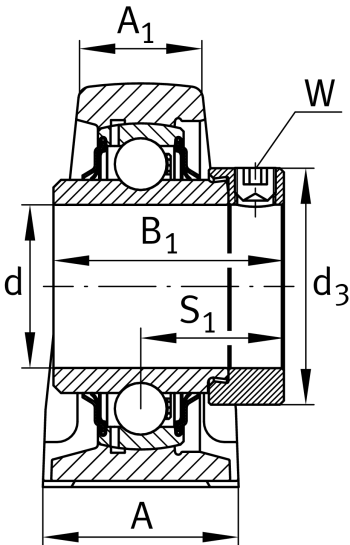

Your current product variant

Material	GG	Grey cast iron
----------	----	----------------

Main Dimensions & Performance Data

d	100 mm	Bore diameter
L	440 mm	Length total
H ₂	280 mm	Height
C _r	184.000 N	Basic dynamic load rating, radial
C _{0r}	141.000 N	Basic static load rating, radial
≈m	37,1 kg	Weight

Mounting dimensions

J	375 mm	Distance fixing bore
N	32 mm	Width (slot)
N ₁	47 mm	Length (slot)



Dimensions

H	145 mm	Distance shaft axis
A	130 mm	Width (base)
A ₁	94 mm	Width (head)
H ₁	65 mm	Height (base)
B ₁	109,4 mm	Locking collar total width
S ₁	69,9 mm	Distance of raceway to locking collar
Q	M6	Connection thread for lubrication

Additional information

GEHSAO20-GG	Housing
GNE100-XL-KRR-B	Bearing designation

Temperature range

T _{min}	-20 °C	Operating temperature min.
T _{max}	120 °C	Operating temperature max.