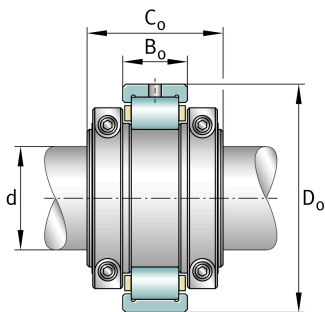
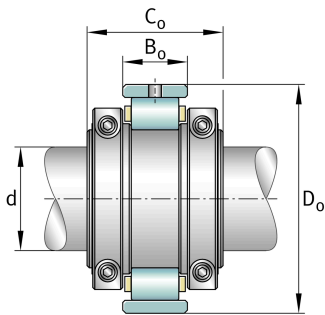

**FAG****S1B-100MM-HD** [↗](#)

Plummer block housing unit

FAG split cylindrical roller bearing housing

## Technical information

**Main Dimensions & Performance Data**

d	100 mm	Shaft diameter
≈m	6,305 kg	Weight

**Dimensions**

	S1B-100MM-FL	Bearing float
	S1B-100MM-HD	Bearing held
$C_a$	2,437,504 N	Basic dynamic load rating, axial
$C_r$	226.278,656 N	Basic dynamic load rating, radial
$C_{0r}$	322.800,256 N	Basic static load rating, radial
	2.400 1/min	Limiting speed
$D_0$	174,625 mm	Outside diameter bearing
$C_0$	80,975 mm	Width inner ring
$B_0$	45,237 mm	Width outer ring