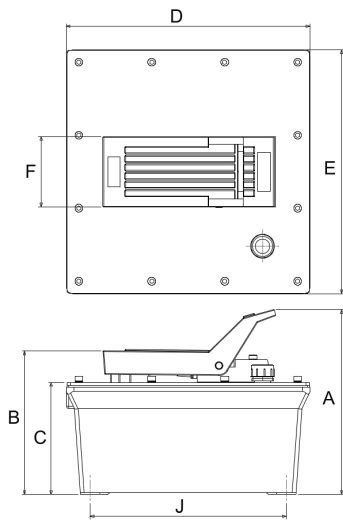

**AP-8000S-HN-SET**

Hydraulic pump, air-driven

BETEX Air-hydraulic foot pump, 700 bar,  
in set with pressure gauge, T-piece, hose,  
couplings and steel box

## Technical information

**Your current product variant**

Series	AP	Air-hydraulic pump
Version	HN	For use with hydraulic nuts

**Technical data**

P max	700 bar	Maximum operating pressure
V	195 cm <sup>3</sup> @ 700 bar	Oil flow/minute
V max	8 l	Volume of oil container
V eff	7,2 l	Useable oil quantity
P AIR	7 – 10 bar	Required pressure in the air supply
	3/8" NPT	Hose connection pump body
	Quick coupling G $\frac{1}{4}$	Coupling
	19,1 kg	Weight pump
	660 x 380 x 310	Dimensions steel case (mm)
≈m	23,2 kg	Weight

**Dimensions**

A	236 mm
B	184 mm
C	143 mm
D	311,6 mm
E	311,6 mm
F	90 mm
J	251 mm



### Additional information

---

preferably in  
combination with  
hydraulic nuts  
HYDNUT

Use

### Related products

---

HYDNUT..E  
HYDNUT..E-INCH  
HYDNUT..HEAVY