

**KR16-PP-RR-A**

Stud type track roller

Stud type track rollers KR..-PP-A, single row needle roller bearings with particularly thick-walled outer ring, needle roller and cage assembly and a solid roller stud with fixing thread and a mounting aid, axial guidance of outer ring is provided by the plastic axial plain washers, contact flange and contact washer, three-stage sealing by plastic axial plain washer on both sides, without eccentric collar

Technical information

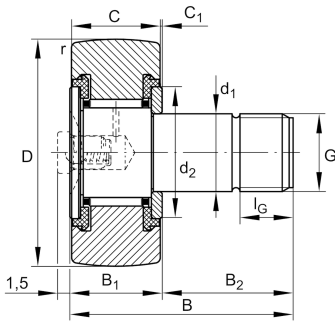

Your current product variant

Sealing	PP	Three-stage sealing by plastic axial plain washer on both sides
Outer ring profile	IOP	Optimized INA-profile
Grease nipples	1x	Drive-fit lubrication nipple unmounted 1x
Relubrication facility	K	Via head
Assembling aid head	SL	Mounting slot
Coating	RR	Protected against corrosion by Corrotect special coating

Main Dimensions & Performance Data

D	16 mm	Outside diameter
d ₁	6 mm	Fit diameter of roller stud / stud
B	28 mm	Width of the roller stud
C _{r w}	3.200 N	Basic dynamic load rating, radial
C _{0 r w}	3.450 N	Basic static load rating, radial
C _{u r w}	465 N	Fatigue load limit, radial
n _{D G}	14.000 1/min	Speed on permanent grease lubrication
≈m	0,017 kg	Weight



Dimensions

B ₁	12,2 mm	Maximum width of thrust washer
B ₂	16 mm	Bolt/stud length effectively
C	11 mm	Width, outer ring
C ₁	0,6 mm	Protrusion outer ring to thrust washer
r _{min}	0,15 mm	Minimum chamfer dimension
d ₂	12,5 mm	Stop diameter of thrust washer
G	M6	Thread
l _G	8 mm	Thread length

Additional information

	NIPA1	Drive-fit lubrication nipple
	1,5 mm	Protrusion lubrication nipple
M _A	3 Nm	Tightening torque nut