

**RASEY45-XL**

## Plummer block housing unit

Plummer block housing units RASEY, cast iron housing, radial insert ball bearing with grub screws in inner ring, R seals

X-life

## Technical information

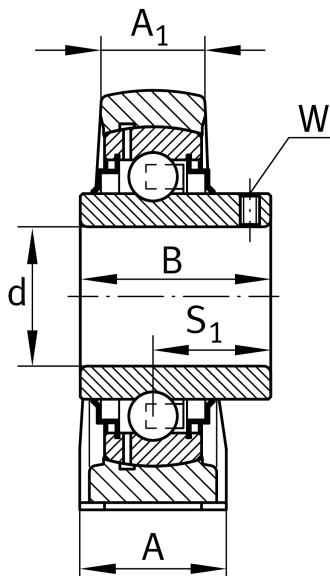

## Your current product variant

Material	GG	Grey cast iron
----------	----	----------------

## Main Dimensions &amp; Performance Data

d	45 mm	Bore diameter
L	192 mm	Length total
H <sub>2</sub>	107 mm	Height
≈m	2,16 kg	Weight

## Mounting dimensions

J	149,65 mm	Distance fixing bore
N	14 mm	Width (slot)
N <sub>1</sub>	29 mm	Length (slot)

## Dimensions

H	54 mm	Distance shaft axis
A	48 mm	Width (base)
A <sub>1</sub>	32 mm	Width (head)
H <sub>1</sub>	21,5 mm	Height (base)
B	49,2 mm	Width
S <sub>1</sub>	30,2 mm	Distance of raceway to locking collar
Q	M6	Connection thread for lubrication



### Additional information

ASE09	Housing
GYE45-XL-KRR-B	Bearing designation

### Temperature range

T <sub>min</sub>	-20 °C	Operating temperature min.
T <sub>max</sub>	100 °C	Operating temperature max.