

**TASE75-XL**

Plummer block housing unit

Plummer block housing units TASE, cast iron housing, radial insert ball bearing with eccentric locking collar, T seals

X-life

Technical information

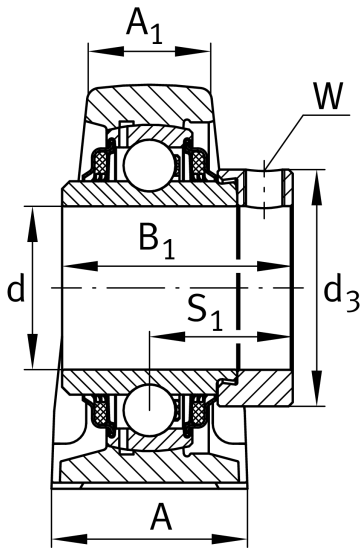

Your current product variant

Material	GG	Grey cast iron
----------	----	----------------

Main Dimensions & Performance Data

d	75 mm	Bore diameter
L	265 mm	Length total
H ₂	164 mm	Height
≈m	6,646 kg	Weight

Mounting dimensions

J	210 mm	Distance fixing bore
N	22 mm	Width (slot)
N ₁	30 mm	Length (slot)

Dimensions

H	82,5 mm	Distance shaft axis
A	66 mm	Width (base)
A ₁	48 mm	Width (head)
H ₁	27,5 mm	Height (base)
B ₁	67 mm	Locking collar total width
S ₁	45,5 mm	Distance of raceway to locking collar
Q	M6	Connection thread for lubrication



Additional information

ASE15	Housing
GE75-XL-KTT-B	Bearing designation

Temperature range

T _{min}	-20 °C	Operating temperature min.
T _{max}	120 °C	Operating temperature max.