

**RSHE50-XL-N**

Plummer block housing unit

Plummer block housing units RSHE, cast iron housing, radial insert ball bearing with eccentric locking collar, R seals

X-life

Technical information

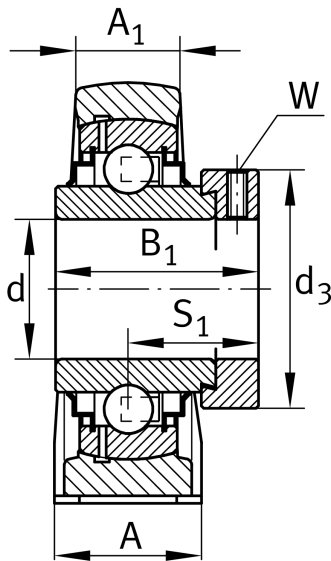

Your current product variant

Groove	N	Cast iron housing with undercut slot for end caps
Material	GG	Grey cast iron

Main Dimensions & Performance Data

d	50 mm	Bore diameter
L	135 mm	Length total
H ₂	115 mm	Height
≈m	2,48 kg	Weight

Mounting dimensions

J	101,6 mm	Distance fixing bore
K	M16	Thread fixing bore

Dimensions

H	57,2 mm	Distance shaft axis
A	54 mm	Width (base)
A ₁	34 mm	Width (head)
Q	M6	Connection thread for lubrication
S ₁	38,2 mm	Distance of raceway to locking collar



Additional information

SHE10	Housing
GE50-XL-KRR-B	Bearing designation
KASK10	Protecting cap

Temperature range

T _{min}	-20 °C	Operating temperature min.
T _{max}	120 °C	Operating temperature max.