

**RSHEY45-XL**

Plummer block housing unit

Plummer block housing units RSHEY, cast iron housing, radial insert ball bearing with grub screws in inner ring, R seals

X-life

Technical information

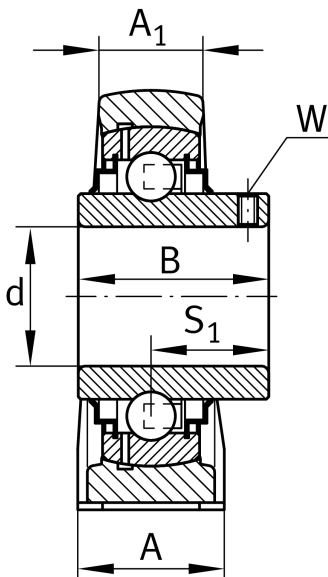

Your current product variant

Material	GG	Grey cast iron
----------	----	----------------

Main Dimensions & Performance Data

d	45 mm	Bore diameter
L	120 mm	Length total
H ₂	107 mm	Height
≈m	2 kg	Weight

Mounting dimensions

J	95,3 mm	Distance fixing bore
K	M12	Thread fixing bore

Dimensions

H	54 mm	Distance shaft axis
A	48 mm	Width (base)
A ₁	32 mm	Width (head)
Q	M6	Connection thread for lubrication
B	49,2 mm	Width of inner ring
S ₁	30,2 mm	Distance of raceway to locking collar



Additional information

SHE09	Housing
GYE45-XL-KRR-B	Bearing designation

Temperature range

T _{min}	-20 °C	Operating temperature min.
T _{max}	120 °C	Operating temperature max.