

**TSHE45-XL**

Plummer block housing unit

Plummer block housing units TSHE, cast iron housing, radial insert ball bearing with eccentric locking collar, T seals

X-life

Technical information

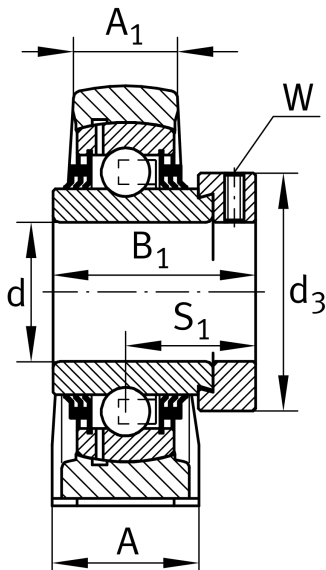

Your current product variant

Material	GG	Grey cast iron
----------	----	----------------

Main Dimensions & Performance Data

d	45 mm	Bore diameter
L	120 mm	Length total
H ₂	107 mm	Height
≈m	2,16 kg	Weight

Mounting dimensions

J	95,3 mm	Distance fixing bore
K	M12	Thread fixing bore

Dimensions

H	54 mm	Distance shaft axis
A	48 mm	Width (base)
A ₁	32 mm	Width (head)
Q	M6	Connection thread for lubrication

Additional information

SHE09	Housing
GE45-XL-KTT-B	Bearing designation



View product details on medias

21.05.2026, 07:17:13 UTC

SCHAEFFLER

Temperature range

T _{min}	-20 °C	Operating temperature min.
------------------	--------	----------------------------

T _{max}	120 °C	Operating temperature max.
------------------	--------	----------------------------