

**PB17-XL**

Plummer block housing unit

Plummer block housing units PB, sheet steel housing, radial insert ball bearing with eccentric locking collar, P seals

X-life

Technical information

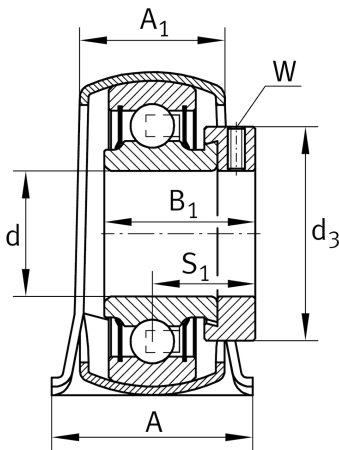
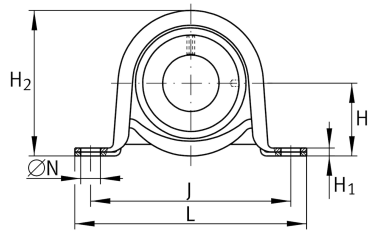

Your current product variant

Material	Steel sheet
----------	-------------

Main Dimensions & Performance Data

d	17 mm	Bore diameter
L	85,7 mm	Length total
H ₂	43,2 mm	Height
C _{0rG}	1.350 N	Load carrying capacity (housing)
C _r	9.800 N	Basic dynamic load rating, radial
C _{0r}	4.750 N	Basic static load rating, radial
≈m	0,17 kg	Weight

Mounting dimensions

J	68 mm	Distance fixing bore
N	9,5 mm	Fixing bore

Dimensions

H	22,2 mm	Distance shaft axis
A	25,4 mm	Width (base)
A ₁	18,4 mm	Width (head)
H ₁	2,6 mm	Height (base)



Additional information

f_0	13	Calculation factor
	GEH40-BT	Housing
	RAE17-XL-NPP-B	Bearing designation

Temperature range

T_{min}	-20 °C	Operating temperature min.
T_{max}	120 °C	Operating temperature max.