

**PB25-XL**

## Plummer block housing unit

Plummer block housing units PB, sheet steel housing, radial insert ball bearing with eccentric locking collar, P seals

X-life

## Technical information

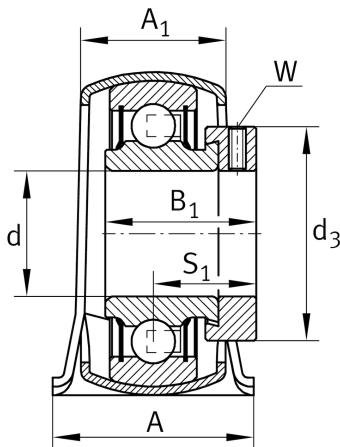
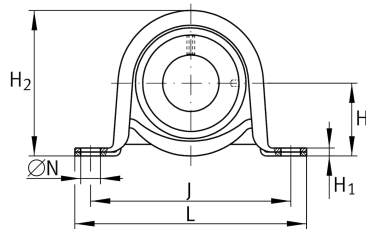

## Your current product variant

Material	Steel sheet
----------	-------------

## Main Dimensions &amp; Performance Data

d	25 mm	Bore diameter
L	108 mm	Length total
H <sub>2</sub>	56,5 mm	Height
C <sub>0rG</sub>	1.800 N	Load carrying capacity (housing)
C <sub>r</sub>	14.000 N	Basic dynamic load rating, radial
C <sub>0r</sub>	7.800 N	Basic static load rating, radial
≈m	0,315 kg	Weight

## Mounting dimensions

J	86 mm	Distance fixing bore
N	11,5 mm	Fixing bore

## Dimensions

H	28,6 mm	Distance shaft axis
A	31,8 mm	Width (base)
A <sub>1</sub>	23,5 mm	Width (head)
H <sub>1</sub>	4 mm	Height (base)



### Additional information

---

f <sub>0</sub>	13,8	Calculation factor
	GEH52-BT	Housing
	RAE25-XL-NPP-B	Bearing designation

### Temperature range

---

T <sub>min</sub>	-20 °C	Operating temperature min.
T <sub>max</sub>	120 °C	Operating temperature max.