

**RPB17-XL**

Plummer block housing unit

Plummer block housing units RPB, sheet steel housing, radial insert ball bearing with eccentric locking collar and rubber interliner, P seals

X-life

Technical information

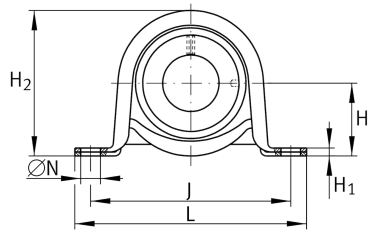
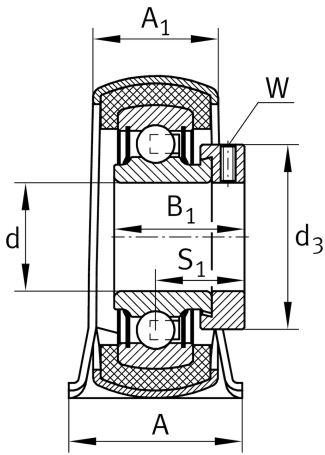

Your current product variant

Material	Steel sheet
----------	-------------

Main Dimensions & Performance Data

d	17 mm	Bore diameter
L	98,4 mm	Length total
H ₂	50,1 mm	Height
C _{0r G}	900 N	Load carrying capacity (housing)
C _r	10.100 N	Basic dynamic load rating, radial
C _{0r}	4.750 N	Basic static load rating, radial
≈m	0,21 kg	Weight

Mounting dimensions

J	76 mm	Distance fixing bore
N	9,5 mm	Fixing bore

Dimensions

H	25,4 mm	Distance shaft axis
A	31,8 mm	Width (base)
A ₁	22,3 mm	Width (head)
H ₁	3,3 mm	Height (base)



Additional information

f_0	13	Calculation factor
	GEH47-BT	Housing
	GRG.RABR40/47	Rubber interliner designation
	RAE17-XL-NPP-B	Bearing designation

Temperature range

T_{min}	-20 °C	Operating temperature min.
T_{max}	120 °C	Operating temperature max.