

**PCJTY30-XL-N**

Flanged housing unit

Housing units PCJTY, two-bolt flanged housing units, cast iron, grub screws in inner ring, P seals

X-life

Technical information

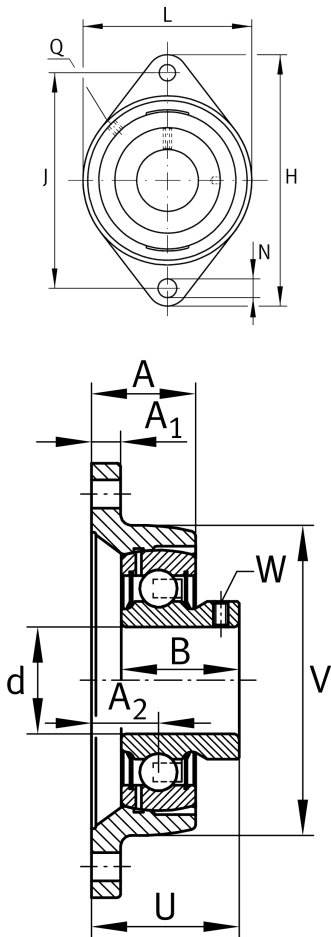

Your current product variant

Groove	N	Cast iron housing with undercut slot for end caps
Material	GG	Grey cast iron

Main Dimensions & Performance Data

d	30 mm	Bore diameter
L	80 mm	Flange width
H	142 mm	Height flange
U	41 mm	Total height unit
C_r	19.500 N	Basic dynamic load rating, radial
C_{0r}	11.300 N	Basic static load rating, radial
C_{ur}	480 N	Fatigue load limit, radial
$\approx m$	0,75 kg	Weight

Mounting dimensions

J	116,5 mm	Distance fixing bore
N	11,5 mm	Fixing bore
W	3 mm	Width across flats
n	2	Number of screwing holes



Dimensions

A	31 mm	Height housing
A ₁	12 mm	Thickness of flange
A ₂	20 mm	Distance raceway
B	30 mm	Width
V	80 mm	Shoulder diameter housing
Q	M6	Connection thread for lubrication

Additional information

GEHCJT06-GG-N	Housing
GAY30-XL-NPP-B	Bearing designation
KASK06	Protecting cap

Temperature range

T _{min}	-20 °C	Operating temperature min.
T _{max}	100 °C	Operating temperature max.