

**PMEY50-XL-N**

## Flanged housing unit

Housing units PMEY, four-bolt flanged housing units, cast iron, centring spigot, grub screws in inner ring, P seals

X-life

## Technical information

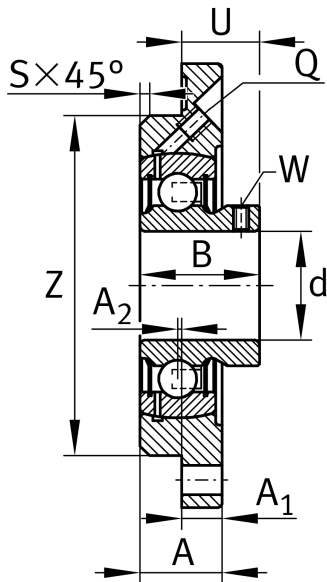

## Your current product variant

Groove	N	Cast iron housing with undercut slot for end caps
Material	GG	Grey cast iron

## Main Dimensions &amp; Performance Data

d	50 mm	Bore diameter
H	165 mm	Height flange
U	31 mm	Total height unit
C <sub>r</sub>	35.000 N	Basic dynamic load rating, radial
C <sub>0r</sub>	23.200 N	Basic static load rating, radial
C <sub>ur</sub>	990 N	Fatigue load limit, radial
m	2,009 kg	Weight

## Mounting dimensions

J	135 mm	Pitch circle diameter (holes)
N	14 mm	Fixing bore
Z	110 mm	Diameter spigot
	h8	Diameter spigot clearance
n	4	Number of screwing holes



### Dimensions

A	25 mm	Height housing
A <sub>1</sub>	13 mm	Thickness of flange
A <sub>2</sub>	1 mm	Distance raceway
B	43 mm	Width
S	3 mm	Chamfer width
Q	M8X1	Connection thread for lubrication

### Additional information

1	Number of housings
ME10	Housing
GAY50-XL-NPP-B	Bearing designation
KASK10	Protecting cap

### Temperature range

T <sub>min</sub>	-20 °C	Operating temperature min.
T <sub>max</sub>	120 °C	Operating temperature max.