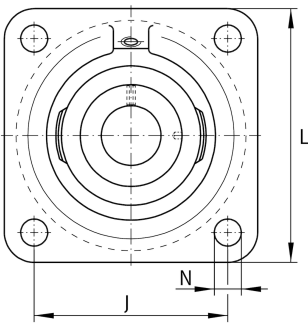

**TCJL30-N-L285** [↗](#)

Flanged housing unit

Flanged housing unit TCJL...-N

## Technical information

**Your current product variant**

Groove	N	Cast iron housing with undercut slot for end caps
Material	GG	Grey cast iron
Lubricant	L285	Grease (L285)

**Main Dimensions & Performance Data**

d	30 mm	Bore diameter
L	108 mm	Flange width
U	42 mm	Total height unit
C <sub>r</sub>	19.500 N	Basic dynamic load rating, radial
C <sub>0r</sub>	11.300 N	Basic static load rating, radial
C <sub>ur</sub>	590 N	Fatigue load limit, radial
≈m	1,07 kg	Weight

**Mounting dimensions**

J	82,5 mm	Distance fixing bore
N	11,5 mm	Fixing bore
n	4	Number of screwing holes



### Dimensions

A	31 mm	Height housing
A <sub>1</sub>	12 mm	Thickness of flange
A <sub>2</sub>	20 mm	Distance raceway
B	36,5 mm	Width
V	85 mm	Shoulder diameter housing
Q	M6	Connection thread for lubrication

### Additional information

GEHCJ06-GG-N	Housing
GLE30-XL-KTT-B-L285	Bearing designation

### Temperature range

T <sub>min</sub>	-40 °C	Operating temperature min.
T <sub>max</sub>	180 °C	Operating temperature max.