

**PCJ17-XL**

Flanged housing unit

Housing units PCJ, four-bolt flanged housing units, cast iron, eccentric locking collar, P seals

X-life

Technical information

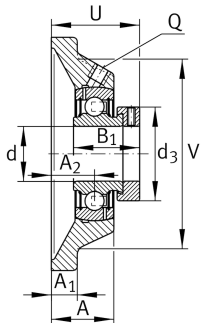
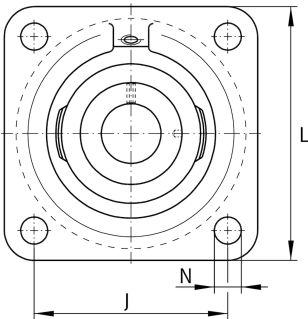
**Your current product variant**

Material	GG	Grey cast iron
----------	----	----------------

Main Dimensions & Performance Data

d	17 mm	Bore diameter
L	76 mm	Flange width
U	39,1 mm	Total height unit
C _r	10.100 N	Basic dynamic load rating, radial
C _{0r}	4.750 N	Basic static load rating, radial
C _{ur}	248 N	Fatigue load limit, radial
≈m	0,45 kg	Weight

Mounting dimensions

J	54 mm	Distance fixing bore
N	11,5 mm	Fixing bore
n	4	Number of screwing holes



Dimensions

A	27 mm	Height housing
A ₁	9,5 mm	Thickness of flange
A ₂	17 mm	Distance raceway
V	58 mm	Shoulder diameter housing
Q	M6	Connection thread for lubrication
d ₃	28,4 mm	Outside diameter locking device

Additional information

1	Number of housings
CJ03	Housing
GRAE17-XL-NPP-B	Bearing designation

Temperature range

T _{min}	-20 °C	Operating temperature min.
T _{max}	120 °C	Operating temperature max.