

**RCJ35-XL-N**

Flanged housing unit

Housing units RCJ, four-bolt flanged housing units, cast iron, eccentric locking collar, R seals

X-life

Technical information

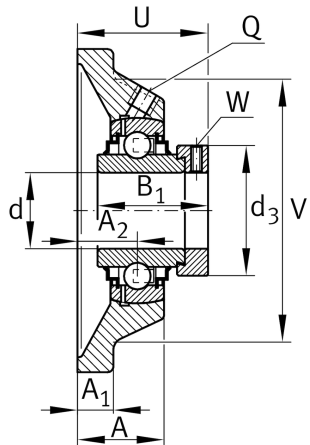
**Your current product variant**

Groove	N	Cast iron housing with undercut slot for end caps
Material	GG	Grey cast iron

Main Dimensions & Performance Data

d	35 mm	Bore diameter
L	118 mm	Flange width
U	53,5 mm	Total height unit
C_r	27.500 N	Basic dynamic load rating, radial
C_{0r}	15.300 N	Basic static load rating, radial
C_{ur}	800 N	Fatigue load limit, radial
m	1,59 kg	Weight

Mounting dimensions

J	92 mm	Distance fixing bore
N	14 mm	Fixing bore
W	5 mm	Width across flats
n	4	Number of screwing holes



Dimensions

A	32,5 mm	Height housing
A ₁	12,5 mm	Thickness of flange
A ₂	21 mm	Distance raceway
B ₁	51,3 mm	Locking collar total width
V	100 mm	Shoulder diameter housing
Q	M6	Connection thread for lubrication
d ₃	55 mm	Outside diameter locking device

Additional information

GEHCJ07-GG-N	Housing
GE35-XL-KRR-B	Bearing designation
KASK07	Protecting cap

Temperature range

T _{min}	-20 °C	Operating temperature min.
T _{max}	120 °C	Operating temperature max.