

**TCJ25-XL-N**

Flanged housing unit

Housing units TCJ, four-bolt flanged housing units, cast iron, eccentric locking collar, T seals

X-life

Technical information



Your current product variant

Groove	N	Cast iron housing with undercut slot for end caps
Material	GG	Grey cast iron

Main Dimensions & Performance Data

d	25 mm	Bore diameter
L	95 mm	Flange width
U	46 mm	Total height unit
C_r	14.900 N	Basic dynamic load rating, radial
C_{0r}	7.800 N	Basic static load rating, radial
C_{ur}	410 N	Fatigue load limit, radial
m	0,81 kg	Weight

Mounting dimensions

J	70 mm	Distance fixing bore
N	11,5 mm	Fixing bore
W	3 mm	Width across flats
n	4	Number of screwing holes

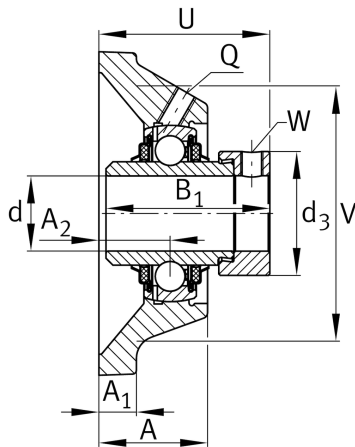



Dimensions

A	29 mm	Height housing
A ₁	11 mm	Thickness of flange
A ₂	19 mm	Distance raceway
B ₁	44,5 mm	Locking collar total width
V	74 mm	Shoulder diameter housing
Q	M6	Connection thread for lubrication
d ₃	37,5 mm	Outside diameter locking device

Additional information

1	Number of housings
CJ05	Housing
GE25-XL-KTT-B	Bearing designation
KASK05	Protecting cap

Temperature range

T _{min}	-20 °C	Operating temperature min.
T _{max}	120 °C	Operating temperature max.