

**RFE35-XL**

## Flanged housing unit

Housing units RFE, four-bolt flanged housing units, cast iron, centring spigot, eccentric locking collar, R seals

X-life

## Technical information

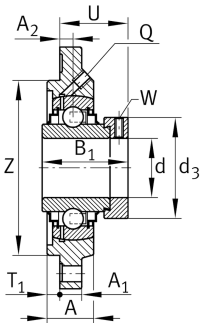
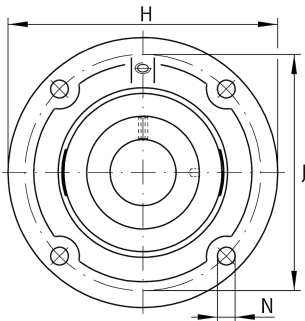

## Your current product variant

Material	GG	Grey cast iron
----------	----	----------------

## Main Dimensions &amp; Performance Data

d	35 mm	Bore diameter
H	135 mm	Flange width
U	41,7 mm	Total height unit
C <sub>r</sub>	25.500 N	Basic dynamic load rating, radial
C <sub>0r</sub>	15.300 N	Basic static load rating, radial
C <sub>ur</sub>	800 N	Fatigue load limit, radial
≈m	1,3 kg	Weight

## Mounting dimensions

J	110 mm	Pitch circle diameter (holes)
N	11,5 mm	Fixing bore
T <sub>1</sub>	4 mm	Height spigot
Z	90 mm	Diameter spigot
	h8	Diameter spigot clearance
W	5 mm	Width across flats
n	4	Number of screwing holes



### Dimensions

A	24,5 mm	Height housing
A <sub>1</sub>	10 mm	Thickness of flange
A <sub>2</sub>	9 mm	Distance raceway
B <sub>1</sub>	51,3 mm	Locking collar total width
Q	M6	Connection thread for lubrication
d <sub>3</sub>	55 mm	Outer diameter locking collar

### Additional information

1	Number of housings
FE07	Housing
GE35-XL-KRR-B	Bearing designation

### Temperature range

T <sub>min</sub>	-20 °C	Operating temperature min.
T <sub>max</sub>	120 °C	Operating temperature max.