

**RFE45-XL**

Flanged housing unit

Housing units RFE, four-bolt flanged housing units, cast iron, centring spigot, eccentric locking collar, R seals

X-life

Technical information

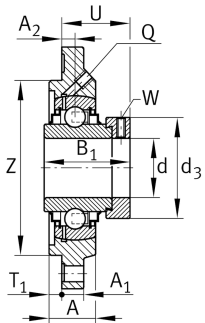
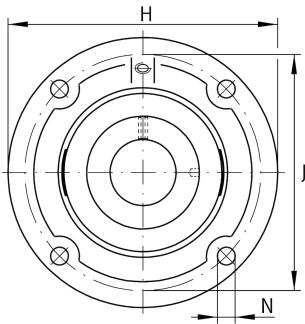

Your current product variant

Material	GG	Grey cast iron
----------	----	----------------

Main Dimensions & Performance Data

d	45 mm	Bore diameter
H	155 mm	Height flange
H	155 mm	Flange width
U	46,4 mm	Total height unit
C _r	32.500 N	Basic dynamic load rating, radial
C _{0r}	20.400 N	Basic static load rating, radial
C _{ur}	970 N	Fatigue load limit, radial
≈m	2,01 kg	Weight

Mounting dimensions

J	130 mm	Distance fixing bore
J	130 mm	Pitch circle diameter (holes)
N	14 mm	Fixing bore
T ₁	4 mm	Height spigot
Z	105 mm	Diameter spigot
	h8	Diameter spigot clearance
n	4	Number of screwing holes



Dimensions

A	26,5 mm	Height housing
A ₁	12 mm	Thickness of flange
A ₂	11,5 mm	Distance raceway
B ₁	56,5 mm	Locking collar total width
Q	M6	Connection thread for lubrication

Additional information

1	Number of housings
GG.FE09	Housing
GE45-XL-KRR-B	Bearing designation

Temperature range

T _{min}	-20 °C	Operating temperature min.
T _{max}	120 °C	Operating temperature max.