

**TFE30-XL**

Flanged housing unit

Housing units TFE, four-bolt flanged housing units, cast iron, centring spigot, eccentric locking collar, T seals

X-life

Technical information

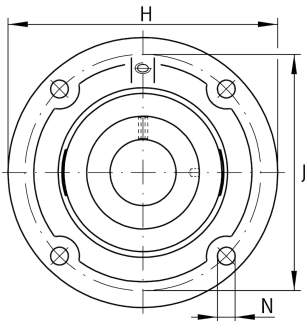
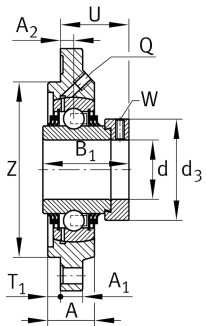

Your current product variant

Material	GG	Grey cast iron
----------	----	----------------

Main Dimensions & Performance Data

d	30 mm	Bore diameter
H	127 mm	Flange width
U	40,7 mm	Total height unit
C _r	20.700 N	Basic dynamic load rating, radial
C _{0r}	11.300 N	Basic static load rating, radial
C _{ur}	590 N	Fatigue load limit, radial
≈m	1,05 kg	Weight

Mounting dimensions

J	105 mm	Pitch circle diameter (holes)
N	9 mm	Fixing bore
T ₁	3 mm	Height spigot
Z	85 mm	Diameter spigot
	h8	Diameter spigot clearance
n	4	Number of screwing holes



Dimensions

A	24,5 mm	Height housing
A ₁	9,5 mm	Thickness of flange
A ₂	10,5 mm	Distance raceway
B ₁	48,5 mm	Locking collar total width
Q	M6	Connection thread for lubrication
d ₃	44 mm	Outer diameter locking collar

Additional information

FE06	Housing
GE30-XL-KTT-B	Bearing designation

Temperature range

T _{min}	-20 °C	Operating temperature min.
T _{max}	100 °C	Operating temperature max.