

**PTUE25-XL**

## Take-up housing unit

Take-up housing units PTUE, cast iron housing, radial insert ball bearing with eccentric locking collar, P seals

X-life

## Technical information

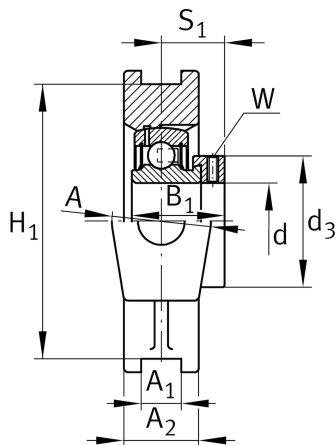

## Your current product variant

Material	GG	Grey cast iron
----------	----	----------------

## Main Dimensions &amp; Performance Data

d	25 mm	Bore diameter
H	90 mm	Height
L	98,5 mm	Length total
B <sub>1</sub>	31 mm	Locking collar total width
m	0,85 kg	Weight

## Mounting dimensions

A <sub>1</sub>	12 mm	Width guidance groove
	H13	Width guidance groove clearance
H <sub>1</sub>	76 mm	Distance guidance grooves
	0,15 mm	Upper distance guidance groove tolerance
	-0,15 mm	Lower distance guidance groove tolerance
N	19 mm	Fixing bore



### Dimensions

L <sub>1</sub>	62 mm	Distance shaft axis
L <sub>2</sub>	10 mm	Length fixed link
L <sub>3</sub>	50 mm	Length guidance groove
A	37 mm	Width housing fixing side
N <sub>1</sub>	18 mm	Width recess
N <sub>2</sub>	32 mm	Height recess
S <sub>1</sub>	23,5 mm	Distance of raceway to locking collar
T	51 mm	Height housing fixing side
Q	M6	Connection thread for lubrication
A <sub>2</sub>	25 mm	Width housing

### Additional information

TUE05	Housing
GRAE25-XL-NPP-B	Bearing designation

### Temperature range

T <sub>min</sub>	-20 °C	Operating temperature min.
T <sub>max</sub>	120 °C	Operating temperature max.