

**PTUE55-XL**

Take-up housing unit

Take-up housing units PTUE, cast iron housing, radial insert ball bearing with eccentric locking collar, P seals

X-life

Technical information

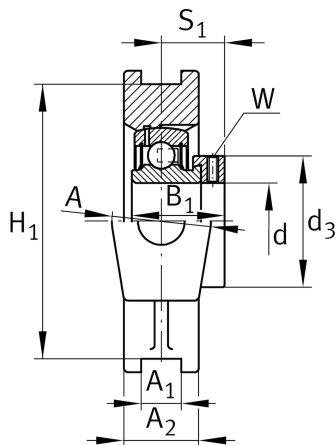

Your current product variant

Material	GG	Grey cast iron
----------	----	----------------

Main Dimensions & Performance Data

d	55 mm	Bore diameter
H	145 mm	Height
L	169 mm	Length total
B ₁	48,4 mm	Locking collar total width
m	4,01 kg	Weight

Mounting dimensions

A ₁	22 mm	Width guidance groove
	H13	Width guidance groove clearance
H ₁	130 mm	Distance guidance grooves
	0,15 mm	Upper distance guidance groove tolerance
	-0,15 mm	Lower distance guidance groove tolerance
N	35 mm	Fixing bore



Dimensions

L ₁	104 mm	Distance shaft axis
L ₂	17 mm	Length fixed link
L ₃	95 mm	Length guidance groove
A	60 mm	Width housing fixing side
N ₁	26 mm	Width recess
N ₂	63,5 mm	Height recess
S ₁	35,9 mm	Distance of raceway to locking collar
T	102 mm	Height housing fixing side
Q	M6	Connection thread for lubrication
A ₂	42 mm	Width housing

Additional information

TUE11	Housing
GRAE55-XL-NPP-B	Bearing designation

Temperature range

T _{min}	-20 °C	Operating temperature min.
T _{max}	120 °C	Operating temperature max.