

**PHEY25-XL**

Take-up housing unit

Take-up housing units PHEY, cast iron housing, radial insert ball bearing with grub screws in inner ring, P seals

X-life

Technical information

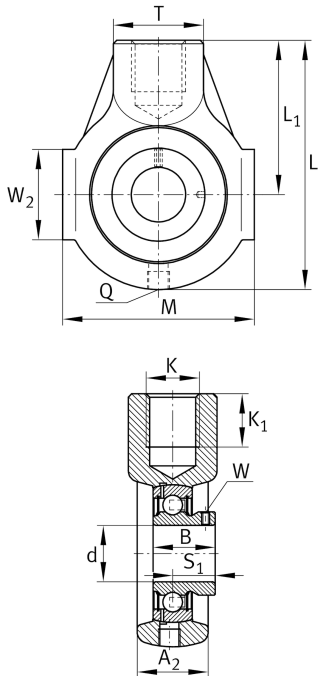

Your current product variant

Material	GG	Grey cast iron
----------	----	----------------

Main Dimensions & Performance Data

d	25 mm	Bore diameter
L	99 mm	Length total
M	70 mm	Housing total width
A ₂	28 mm	Width housing
m	0,66 kg	Weight

Mounting dimensions

K	M20	Thread fixing bore
K ₁	22 mm	Thread depth

Dimensions

L ₁	64 mm	Distance shaft axis
T	35 mm	Height housing fixing side
W ₂	38 mm	Length of guidance face
Q	M6	Connection thread for lubrication



Additional information

HE05	Housing
GAY25-XL-NPP-B	Bearing designation

Temperature range

T _{min}	-20 °C	Operating temperature min.
T _{max}	120 °C	Operating temperature max.