**PHUSE30-XL** [↗](#)

Take-up housing unit

Take-up housing units PHUSE, cast iron and sheet steel housing, radial insert ball bearing with eccentric locking collar, P seals

X-life

Technical information

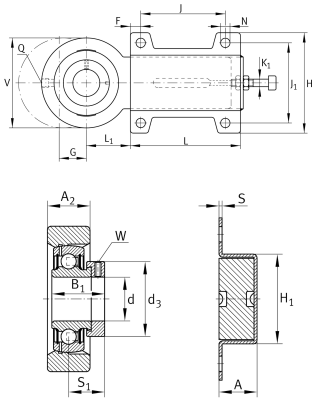

Your current product variant

Material	GG	Grey cast iron
----------	----	----------------

Main Dimensions & Performance Data

d	30 mm	Bore diameter
H	103 mm	Height flange
A	28 mm	Height housing
V	88 mm	Shoulder diameter housing
L	187 mm	Length total
C _{0r} G	11.300 N	Load carrying capacity (housing)
≈m	2,8 kg	Weight

Mounting dimensions

N	11,5 mm	Fixing bore
J	140 mm	Distance fixing bore
J ₁	80 mm	Bore distance width



Dimensions

L ₁	50 mm	Distance shaft axis
A ₂	22 mm	Width housing
H ₁	52 mm	Height guidance
K ₁	M12	Thread adjusting screw
S	4 mm	Thickness of flange
F	20 mm	Distance fixing bore outside
G	65 mm	Axial displacement
Q	M6	Connection thread for lubrication

Additional information

HUE06	Housing
HUSE07	Housing (Part 2)
GRAE30-XL-NPP-B	Bearing designation

Temperature range

T _{min}	-20 °C	Operating temperature min.
T _{max}	120 °C	Operating temperature max.