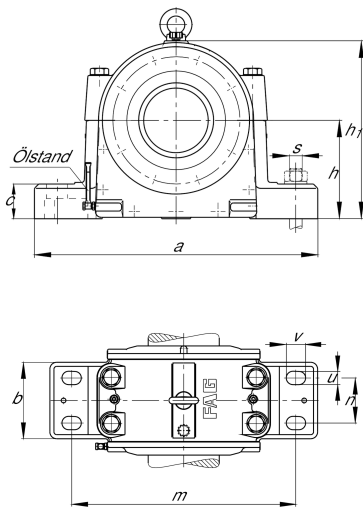

**FAG****LOE536-N-BL-L**

Plummer block housing

Plummer block housing, split, for spherical roller bearings, oil-lubrication

## Technical information

**Main Dimensions & Performance Data**

d	160 mm	Shaft diameter
a	710 mm	Length base
h <sub>1</sub>	465 mm	Height
g <sub>1</sub>	300 mm	Total width
≈m	171 kg	Weight

**Dimensions**

b	200 mm	Width base
c	85 mm	Height base
D	320 mm	Outside diameter bearing
g	210 mm	Width housing body
h	260 mm	Center height
m	580 mm	Distance fixing bore
n	110 mm	Bore distance width
s	M36	Size of fixing screws
u	42 mm	Width slot
v	60 mm	Length slot

**Additional information**

6 l	Oil quantity first filling
110 mm	Maximum height oil level
75 mm	Minimum height oil level



View product details on medias

15.06.2026, 08:26:31 UTC

SCHAEFFLER

### Temperature range

---

T <sub>min</sub>	-20 °C	Operating temperature min.
------------------	--------	----------------------------

T <sub>max</sub>	100 °C	Operating temperature max.
------------------	--------	----------------------------