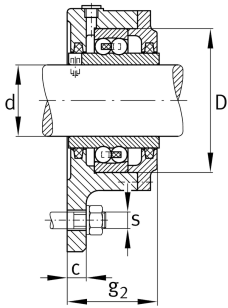
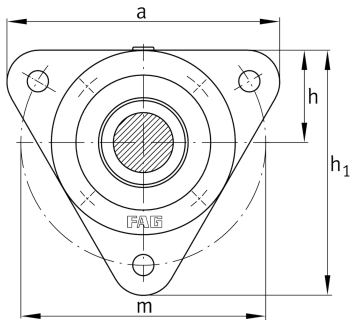
**FAG****F11207**

Flanged housing

Flanged housing for self-aligning ball bearing
112 with wide inner-ring, felt seal, grease
lubrication

Technical information

**Main Dimensions & Performance Data**

d	35 mm	Shaft diameter
a	145 mm	Flange width
g ₂	54 mm	Total width with cover
h ₁	129,5 mm	Height flange
≈m	1,75 kg	Weight

Dimensions

	M10x1	Connection thread for lubrication
c	12 mm	Thickness of flange
D	72 mm	Outside diameter bearing
h	48,5 mm	Distance shaft axis
m	130 mm	Pitch circle diameter fixing holes
s	M12	Size of fixing screws

Temperature range

T _{min}	-20 °C	Operating temperature min.
T _{max}	100 °C	Operating temperature max.