

### SRM01

#### Measuring instrument rpm

Measuring heads, with shims and electronic evaluation system

## Technical information

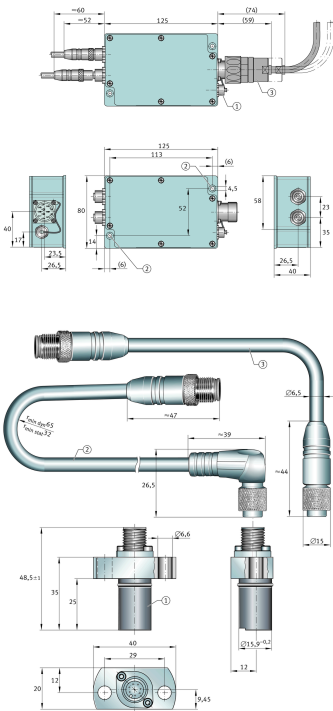

### Digital Output

	SIN COS 1Vpp + reference signal	Electronic interface
≈m	0,55 kg	Weight

### Power Supply

	5 V DC	Supply voltage
	280 mA	Current consumption

### Mounting dimensions

	6,6 mm	Bore diameter sensor SRMH
	29 mm	Bore pitch width sensor SRMH

### Main dimensions

	125 mm	Length SRMB exclud plugs
	80 mm	Width SRMB
	40 mm	Height SRMB
	236 mm	Length SRMB total
	48,5 mm	Length SRMH total
	35 mm	Length SRMH excluding plugs
	25 mm	Length SRMH cylindrical housing
	15,9 mm	Diameter sensor housing SRMH
	40 mm	Flange length sensor SRMH
	20 mm	Flange width sensor SRMH



### Temperature range

70 °C	Operating temperature max
IP 65	Ingress protection
0 °C	Operating temperature min

### Additional information

ISO4762 M4X10-8.8	Cylinder head screws SRMB
ISO4762 M6x20-8.8	Cylinder head screws SRMH
10 Nm	Bolting torque max
9 Nm	Bolting torque min

### Cable

M23x1	Thread plug connector
12	Number pins plug connector